

- > Ø 32 ... 100 mm
 - > High performance, stability and reliability
 - > Cylinders and mountings conform to ISO 15552 (ISO 6431, VDMA 24562 and NFE 49-003-1)
 - > Comprehensive range of mountings
- > Polyurethane seals ensure efficient low friction operation and long life

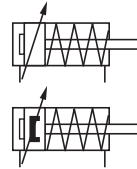

Technical features

Medium:

Compressed air, filtered, lubricated or non-lubricated

Standard:

ISO 15552

Note: all models conform to the mentioned standards except the cylinder size

Operation:

RA/28000: Single acting, sprung in, non-magnetic piston and adjustable cushioning

RA/28000/M: Single acting, sprung in, magnetic piston

and adjustable cushioning

RA/28300: Single acting, sprung out, non-magnetic piston

and adjustable cushioning
RA/28300/M: Single acting, sprung out, magnetic piston

Operating pressure:

2 ... 10 bar (29 ... 145 psi)

Port size:

G1/8 ... G1/2

Cylinder diameters:

32, 40, 50, 63, 80, 100 mm

Strokes:

See table below

Non-standard strokes:

Available 250 mm max.

Operating temperature:

-20 ... +80°C (-4 ... +176°F)

Air supply must be dry enough to avoid ice formation at temperatures below +2°C (+35°F).

Materials:

Barrel: anodised aluminium,
End covers: pressure diecast aluminium
Piston rod: stainless steel (martensitic)
Piston rod seals: PUR
Piston seals: PUR
O-rings: NBR

Technical data





Cylinder Ø (mm)	32	40	50	63	80	100
Port size	G 1/8	G 1/4	G 1/4	G 3/8	G 3/8	G 1/2
Piston rod Ø (mm)	12	16	20	20	25	25
Piston rod thread	M10 x 1,25	M12 x 1,25	M16 x 1,5	M16 x 1,5	M20 x 1,5	M20 x 1,5
Cushion length (mm)	19	22	24	24	27	34
Initial cushion volume (cm ³)	12,3	20,7	36	64	116	242
Air consumption at 6 bar outstroke (l/cm)	0,056	0,088	0,137	0,218	0,35	0,55
Air consumption at 6 bar instroke (l/cm)	0,048	0,074	0,114	0,195	0,32	0,51
RA/28000/M, RA/28000 (28100)						
Theoretical thrusts at 6 bar outstroke (N)	392	648	1043	1735	2795	4492
F1 (N)	50	60	75	75	130	130
RA/28300/M, RA/28300						
Theoretical thrusts at 6 bar instroke (N)	324	528	854	1546	2501	4197
F1 (N)	50	60	75	75	130	130

F1 = Final return force of spring

Standard strokes

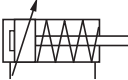
Cylinder Ø (mm)	Stroke length (mm)			
	25	50	80	100
32	•	•	•	•
40	•	•	•	•
50	•	•	•	•
63	•	•	•	•
80	•	•	•	•
100	•	•	•	•

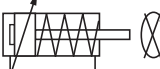
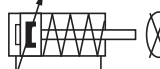
Cylinder variants

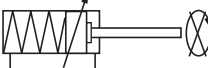
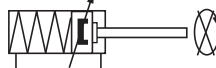
Symbol	Model Non-magnetic piston		Symbol	Model magnetic piston		Description	Dimensions
	C	S		C	S		Page
	•	• RA/28000		•	• RA/28000/M	Standard cylinder, sprung in	6
		RA/28000/W1			RA/28000/W2	Cylinder with special wiper/seal, suitable for applications with arizona sand, cement, plaster (stucco), hoar-frost or ice	
		RA/28000/N1			RA/28000/N2	Cylinder with non-rotating piston rod	7
	•	• RA/28300		•	• RA/28300/M	Standard cylinder, sprung out	6
		RA/28300/W1			RA/28300/W2	Cylinder with special wiper/seal, suitable for applications with arizona sand, cement, plaster (stucco), hoar-frost or ice	
		RA/28300/N1			RA/28300/N2	Cylinder with non-rotating piston rod	6

For the cylinder models style C and S see options selector

Option selector
★A/28★/★/★/★

Piston rod material	Substitute
Stainless steel martensitic	R
Hard chromium plated	C
Stainless steel austenitic	S
Operation	Substitute
Sprung in (Ø 32 ... 80 mm)	0
Sprung in (Ø 100 mm only)	1
Sprung out	3
Cylinder Ø	Substitute
32	32
40	40
50	50
63	63
80	80
100 (Sprung out)	10
100 (Sprung in)	00

Strokes (mm)	Substitute
250 max.	
Variants (magnetic piston)	Substitute
Standard	M
Non-rotating piston rod	N2
Special wiper/seal	W2
Variants (non-magnetic piston)	Substitute
Standard	None
Non-rotating piston rod	N1
Special wiper/seal	W1

Note: If option is not required, disregard option position within part number eg. RA/28100/M/50. For combinations of cylinder variants consult our Technical Service.







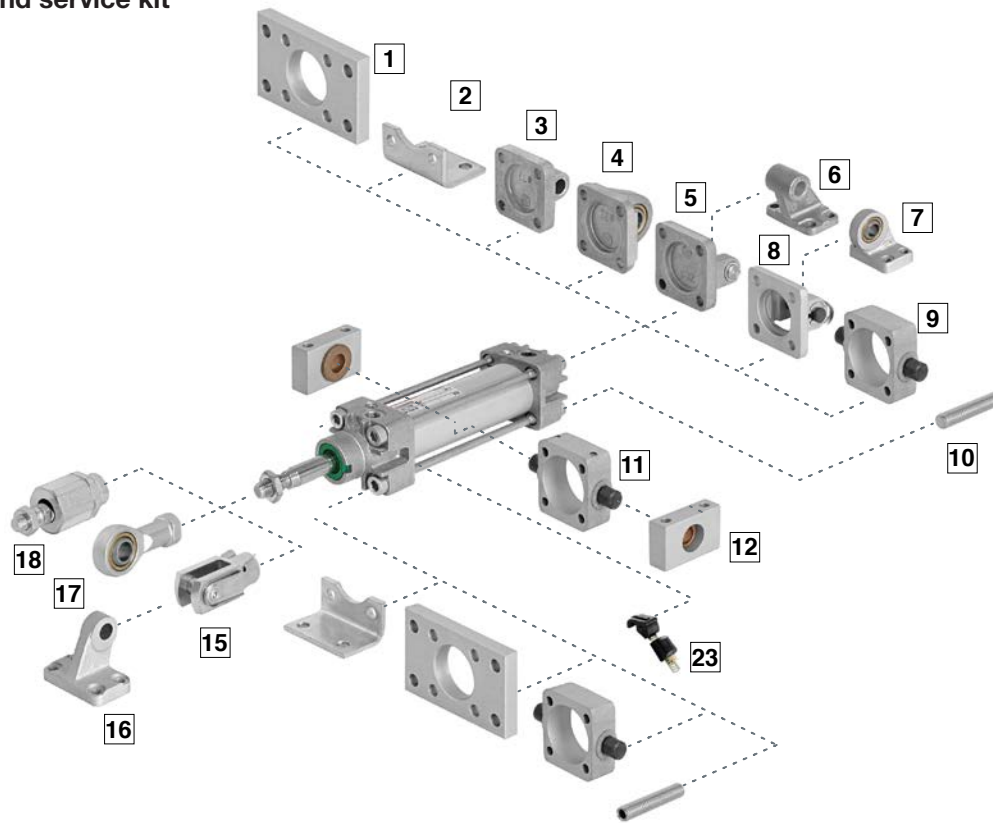

This options selector explains only the cylinder variants.









Additional variants/options are not possible.

Mountings and service kit









Mountings

Model	A	AK	B, G	C	D	D2	F	FH	H
									
Cyl. Ø	10	18	1	2	5	8	15	9	11
	Page 7	Page 7	Page 7	Page 7	Page 8	Page 8	Page 8	Page 8	Page 9
32	QM/8032/35	QM/8025/38	QA/8032/22	QA/8032/21	QA/8032/23	QA/8032/42	QM/8025/25	QA/8032/34	QA/8032/28
40	QM/8032/35	QM/8040/38	QA/8040/22	QA/8040/21	QA/8040/23	QA/8040/42	QM/8040/25	QA/8040/34	QA/8040/28
50	QM/8050/35	QM/8050/38	QA/8050/22	QA/8050/21	QA/8050/23	QA/8050/42	QM/8050/25	QA/8050/34	QA/8050/28
63	QM/8050/35	QM/8050/38	QA/8063/22	QA/8063/21	QA/8063/23	QA/8063/42	QM/8050/25	QA/8063/34	QA/8063/28
80	QM/8080/35	QM/8080/38	QA/8080/22	QA/8080/21	QA/8080/23	QA/8080/42	QM/8080/25	QA/8080/34	QA/8080/28
100	QM/8080/35	QM/8080/38	QA/8100/22	QA/8100/21	QA/8100/23	QA/8100/42	QM/8080/25	QA/8100/34	QA/8100/28

Model	R	S	SS	SW	UF	UH	UR	US
								
Cyl. Ø	3	12	16	6	17	11	4	7
	Page 9	Page 9	Page 11	Page 10	Page 10	Page 9	Page 10	Page 11
32	QA/8032/27	QA/8032/41	M/P19931	M/P19493	QM/8025/32	PQA/182032/40	QA/8032/33	M/P40310
40	QA/8040/27	QA/8040/41	M/P19932	M/P19494	QM/8040/32	PQA/182040/40	QA/8040/33	M/P40311
50	QA/8050/27	QA/8040/41	M/P19933	M/P19495	QM/8050/32	PQA/182050/40	QA/8050/33	M/P40312
63	QA/8063/27	QA/8063/41	M/P19934	M/P19496	QM/8050/32	PQA/182063/40	QA/8063/33	M/P40313
80	QA/8080/27	QA/8063/41	M/P19935	M/P19497	QM/8080/32	PQA/182080/40	QA/8080/33	M/P40314

Accessories
Magnetically operated switches

Model	M/50/**	Switch mounting brackets for M/50	TQM/31, QM/32, QM/132	Switch mounting brackets for TQM/31, QM/32, QM/132	QM/140	Switch mounting brackets for QM/140
						
Cyl. Ø		23				
	Page 12 & 13	Page 13	Page 14	Page 15	Page 16	Page 16
32		QM/27/2/1		QM/31/032/22		QM/140/010/22
40		QM/27/2/1		QM/31/032/22		QM/1w40/010/22
50		QM/27/2/1		QM/31/032/22		QM/140/010/22
63		QM/27/2/1		QM/31/032/22		QM/140/010/22
80		QM/27/2/1		QM/31/080/22		QM/140/010/22
100		QM/27/2/1		QM/31/080/22		QM/140/010/22

Service kit

Model	Service kit
	
Cyl. Ø	
32	QA/8032/00
40	QA/8040/00
50	QA/8050/00
63	QA/8063/00
80	QA/8080/00
100	QA/8100/00

Dimensions
RA/28000, RA/28000/M
Standard cylinder
Sprung in

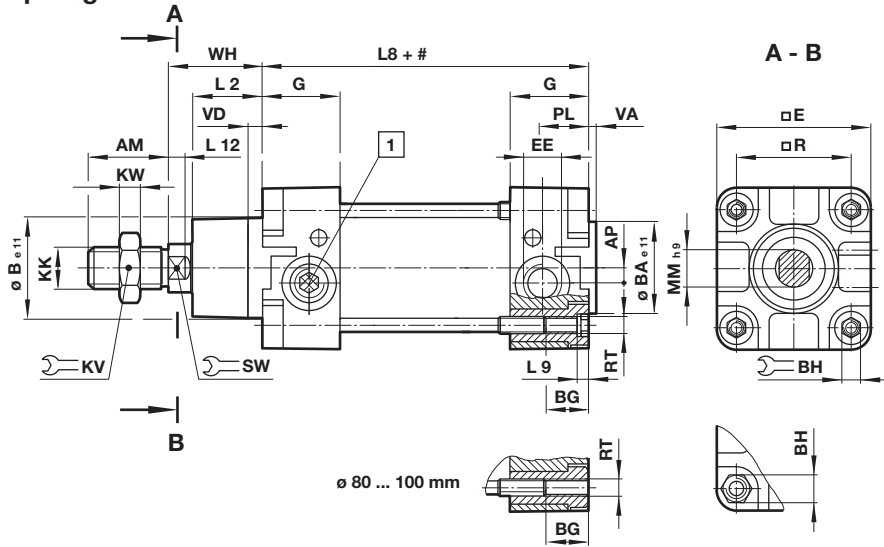

Dimensions in mm
Projection/First angle
RA/28300, RA/28300/M
Standard cylinder
Sprung out

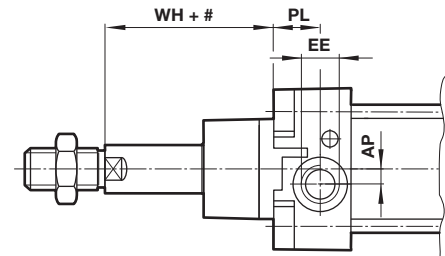

Stroke

Ø	AM	AP	Ø Be 11	Ø BAe 11	BG	BH	q E	EE	G	KK	KV	
32	22	3,5	30	30	16	6	47	G 1/8	27,5	M10x1,25	17	
40	24	4,5	35	35	16	6	53	G 1/4	32	M12x1,25	19	
50	32	6	40	40	16	8	65	G 1/4	31	M16x1,5	24	
63	32	10	45	45	16	8	75	G 3/8	33	M16x1,5	24	
80	40	8,5	45	45	17	19	95	G 3/8	33	M20x1,5	30	
100	40	9	55	55	17	19	115	G 1/2	37	M20x1,5	30	
Ø	KW	L2	L8	L9	L12	Ø MMh 9	PL	q R	RT	SW	VA	
32	5	20	94	4	6	12	13	32,5	M 6	10	3	
40	6	22	105	4	6,5	16	15	38	M 6	13	3,5	
50	8	27	106	5	8	20	18,5	46,5	M 8	17	3,5	
63	8	29	121	5	8	20	19	56,5	M 8	17	4	
80	10	33	128	-	10	25	19	72	M 10	22	4	
100	10	36	138	-	10	25	18	89	M 10	22	4	
Ø	VD	WH	at 0 mm		per 25 mm		Model Non-magnetic piston		Model Magnetic piston			
32	6	26	0,51 kg		0,06 kg		RA/28#32/*		RA/28#32/M/*			
40	6	30	0,80 kg		0,08 kg		RA/28#40/*		RA/28#40/M/*			
50	6	37	1,33 kg		0,12 kg		RA/28#50/*		RA/28#50/M/*			
63	6	37	1,80 kg		0,13 kg		RA/28#63/*		RA/28#63/M/*			
80	6	46	3,25 kg		0,20 kg		RA/28#80/*		RA/28#80/M/*			
100	6	51	4,81 kg		0,23 kg		RA/28100/* or RA/28310/*		RA/28100/M/* or RA/28310/M/*			
28032	28332	28040	283040	28050	28350	28063	28363	28080	28380	28100	28310	Model
25, 50	80, 100	25, 50	80, 100	25, 50	80, 100	25, 50	80, 100	25, 50	80, 100	25, 50	80, 100	Standard strokes
119	147	130	158	131	159	146	174	153	181	163	191	L8
119 + (N * x 28)	130 + (N * x 28)	131 + (N * x 28)	146 + (N * x 28)	153 + (N * x 28)	163 + (N * x 28)							L8
											250 mm max.	non-standard strokes

* Stroke < 50 mm N = 0
Stroke > 50 mm N = $\frac{\text{Stroke} - 1}{50}$ (round up to integer)

Please insert number of spring in (0) or spring out (3).

Cylinder variants

RA/28.00/N1, RA/28.00/N2 – Cylinder with non-rotating piston rod

Dimensions in mm
Projection/First angle



Ø		Torque max (Nm)	Model Non-magnetic piston	Model Magnetic piston
32	10	0,5	RA/28#32/N1/*	RA/28#32/N2/*
40	13	1	RA/28#40/N1/*	RA/28#40/N2/*
50	16	1,5	RA/28#50/N1/*	RA/28#50/N2/*
63	16	1,5	RA/28#63/N1/*	RA/28#63/N2/*
80	16	2,5	RA/28#80/N1/*	RA/28#80/N2/*
100	21	2,5	RA/28100/N1/* or RA/28310/N1/*	RA/28100/N2/* or RA/28310/N2/*

* Please insert standard stroke length.

Please insert number of spring in (0) or spring out (3).

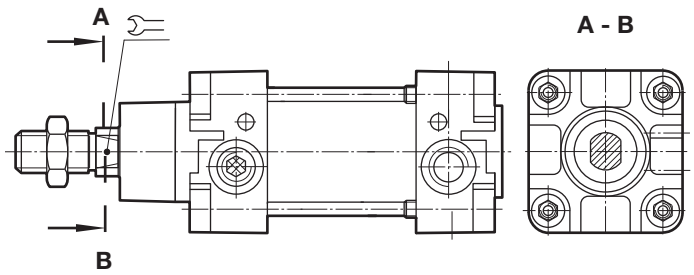

Mountings

Front or rear stud mounting A

Conforms to ISO 15552, type MX1

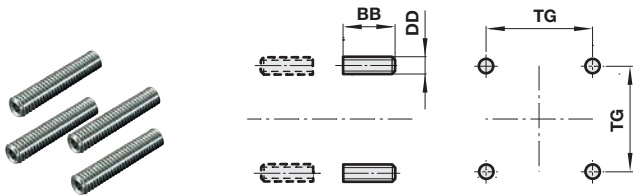

Ø	BB	DD	TG	kg	Model (A)
32/40	17	M6	32,5/38	0,02	QM/8032/35
50/63	23	M8	46,5/56,5	0,05	QM/8050/35
80/100	28	M10	72/89	0,08	QM/8080/35

Piston rod swivel AK

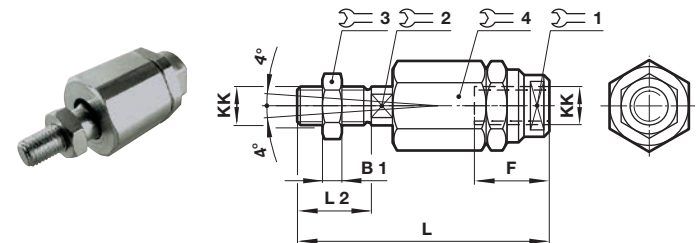

Ø	KK	B1	F	L	L2					kg	Model (AK)
						1	2	3	4		
32	M10x1,25	5	26	73	20	19	12	17	30	0,20	QM/8025/38
40	M12x1,25	6	26	77	24	19	12	19	30	0,20	QM/8040/38
50/63	M16x1,5	8	34	106	32	30	19	24	42	0,65	QM/8050/38

Front flange B, G

Conforms to ISO 15552, type MF1 and MF2

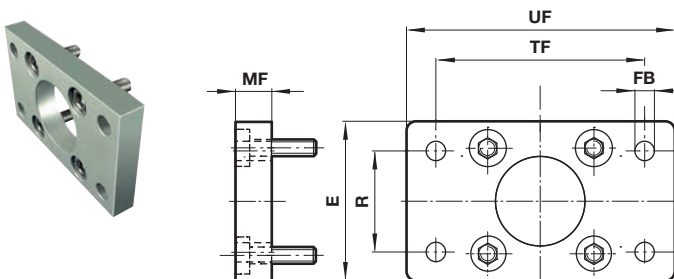

Ø	E	Ø FB	MF	R	TF	UF	kg	Model (B, G)
32	50	7	10	32	64	80	0,25	QA/8032/22
40	55	9	10	36	72	90	0,35	QA/8040/22
50	65	9	12	45	90	110	0,70	QA/8050/22
63	75	9	12	50	100	125	0,80	QA/8063/22
80	100	12	16	63	126	154	1,35	QA/8080/22
100	120	14	16	75	150	186	2,20	QA/8100/22

Foot mounting C

Conforms to ISO 15552, type MS1

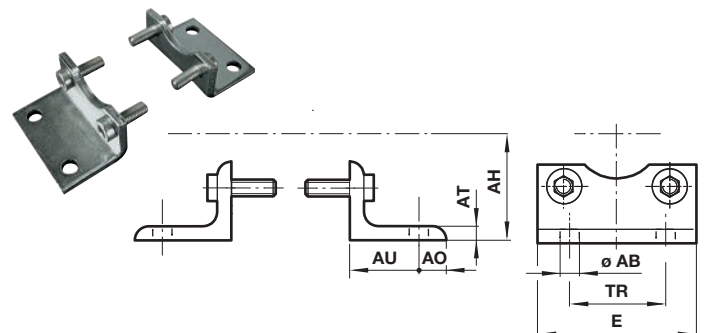

Ø	Ø AB	AH	AO	AT	AU	E	TR	kg	Model (C)
32	7	32	8	4	24	48	32	0,15	QA/8032/21
40	10	36	9	4	28	53	36	0,18	QA/8040/21
50	10	45	10	5	32	64	45	0,30	QA/8050/21
63	10	50	12	5	32	74	50	0,39	QA/8063/21
80	12	63	19	5	41	98	63	0,80	QA/8080/21
100	14	71	19	5	41	115	75	0,95	QA/8100/21

Rear clevis D

Conforms to ISO 1552, type MP2

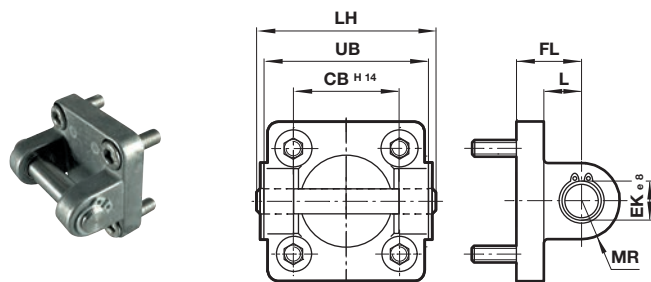

Ø	CB H14	Ø EK e8	FL	L	LH	MR	UB	kg	Model (D)
32	26	10	22	13	52	9	45	0,11	QA/8032/23
40	28	12	25	16	60	12	52	0,16	QA/8040/23
50	32	12	27	17	68	12	60	0,22	QA/8050/23
63	40	16	32	22	79	15	70	0,34	QA/8063/23
80	50	16	36	22	99	15	90	0,54	QA/8080/23
100	60	20	41	27	119	20	110	0,90	QA/8100/23

Rear clevis D2

Conforms to ISO 1552, type AB6

Dimensions in mm
Projection/First angle

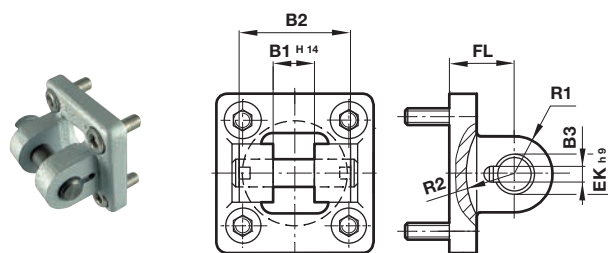

Ø	B1 H14	B2	B3	Ø EK h9	FL	R1	R2	kg	Model (D2)
32	14	34	3,3	10	22	11	17	0,20	QA/8032/42
40	16	40	4,3	12	25	12	20	0,23	QA/8040/42
50	21	45	4,3	16	27	14,5	22	0,36	QA/8050/42
63	21	51	4,3	16	32	18	25	0,55	QA/8063/42
80	25	65	4,3	20	36	22	30	0,90	QA/8080/42
100	25	75	4,3	20	41	22	32	1,45	QA/8100/42

Piston rod clevis F

Conforms to DIN ISO 8140

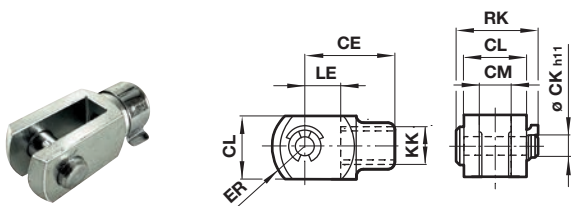

Ø	KK	CE	Ø CK h11	CL	CM	ER	LE	RK	kg	Model (F)
32	M10x1,25	40	10	20	10	16	20	28	0,09	QM/8025/25
40	M12x1,25	48	12	24	12	19	24	32	0,13	QM/8040/25
50/63	M16x1,5	64	16	32	16	25	32	41,5	0,33	QM/8050/25
80/100	M20x1,5	80	20	40	20	32	40	50	0,67	QM/8080/25

Front or rear detachable trunnion FH

Conforms to VDMA 24562 part 2, type MT 5/6

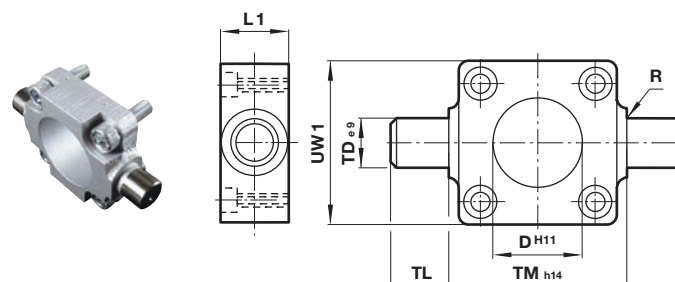

Ø	Ø D h11	L1	R	Ø TD e9	TL	TM h14	UW1	kg	Model (FH)
32	30	16	1	12	12	50	45	0,20	QA/8032/34
40	35	20	1,6	16	16	63	55	0,38	QA/8040/34
50	40	24	1,6	16	16	75	65	0,60	QA/8050/34
63	45	24	1,6	20	20	90	75	1,10	QA/8063/34
80	45	28	1,6	20	20	110	100	1,90	QA/8080/34
100	55	38	2	25	25	132	120	3,50	QA/8100/34

Centre trunnion – H
Conforms to ISO 15552, type MT4

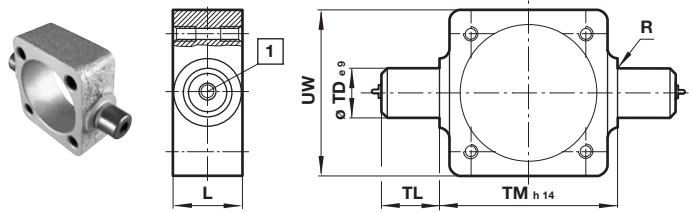

1 Grease nipple up to Ø 125 mm

Ø	L	R	Ø TD e9	TL	TM h14	UW	XV min.	XV max.	kg	Model (H)
32	20	1	12	12	50	50	66	80	0,16	QA/8032/28
40	24	1,6	16	16	63	58	76	89	0,35	QA/8040/28
50	28	1,6	16	16	75	70	82	98	0,65	QA/8050/28
63	28	1,6	20	20	90	80	88	107	0,85	QA/8063/28
80	28	1,6	20	20	110	100	97	123	1,2	QA/8080/28
100	38	2	25	25	132	126	107	128	2,3	QA/8100/28

Note: Style 'H': These mountings are only supplied assembled complete with the cylinder. Unless otherwise specified, units will be supplied with dimension 'XV' plus half the stroke length. 'XV' = Distance from the piston rod shoulder to the centre of the mounting.

Adjustable trunnion mounting UH
Conforms to ISO 15552, type MT4

Dimensions in mm
Projection/First angle

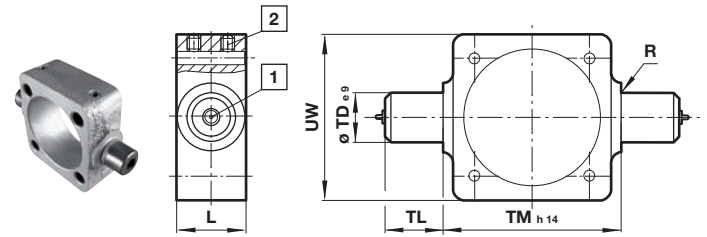

1 Grease nipple up to Ø 125 mm

2 Locking screws

Torque max: Ø 32 & 40 mm = 6 Nm; Ø 50 & 63 mm = 10 Nm;
Ø 80 & 100 mm = 15 Nm

Ø	L	R	Ø TD e9	TL	TM h14	UW	XV min.	XV max.	kg	Model (UH)
32	20	1	12	12	50	50	66	80	0,16	QA/8032/40
40	24	1,6	16	16	63	58	76	89	0,35	QA/8040/40
50	28	1,6	16	16	75	70	82	98	0,65	QA/8050/40
63	28	1,6	20	20	90	80	88	107	0,85	QA/8063/40
80	28	1,6	20	20	110	100	97	123	1,2	QA/8080/40
100	38	2	25	25	132	126	112	128	2,3	QA/8100/40

Style 'UH': It is most important that the locking screws which secure the mounting to the tie rod are tightened to the torque figures shown in the table below. For maximum energy input, consult our Technical Service.

Unless otherwise specified, units will be supplied with dimension 'XV' plus half the stroke length. 'XV' = Distance from the piston rod shoulder to the centre of the mounting.

Rear eye R
Conforms to ISO 15552, type MP4

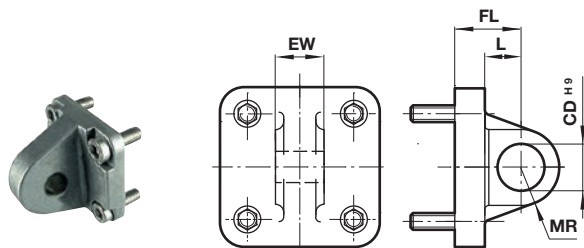

Ø	Ø CD H9	EW	FL	L	MR	kg	Model (R)
32	10	25,8	22	13	9	0,09	QA/8032/27
40	12	27,8	25	16	12	0,11	QA/8040/27
50	12	31,7	27	17	12	0,17	QA/8050/27
63	16	39,7	32	22	15	0,24	QA/8063/27
80	16	49,7	36	22	15	0,37	QA/8080/27
100	20	59,7	41	27	20	0,59	QA/8100/27

Trunnion support S
Conforms to ISO 15552, type AT4

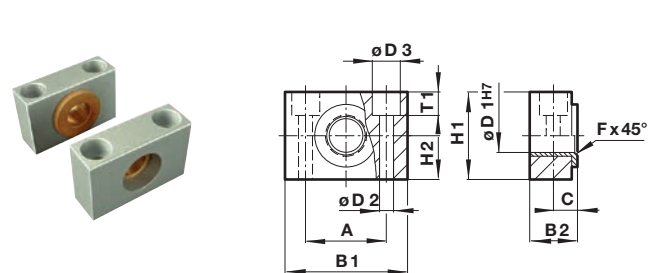

Ø	A	B 1	B 2	C	Ø D1H7	Ø D2	Ø D3	F x 45°	H 1	H 2	T 1	T 2	kg	Model (S)
32	32	46	18	10,5	12	6,6	11	1	30	15	6,8	0,10	QA/8032/41	
40/50	36	55	21	12	16	9	15	1,6	36	18	9	0,14	QA/8040/41	
63/80	42	65	23	13	20	11	18	1,6	40	20	11	0,18	QA/8063/41	
100	50	75	28,5	16	25	14	20	2	50	25	13	0,34	QA/8100/41	

Universal piston rod eye UF
 Conforms to DIN ISO 8139

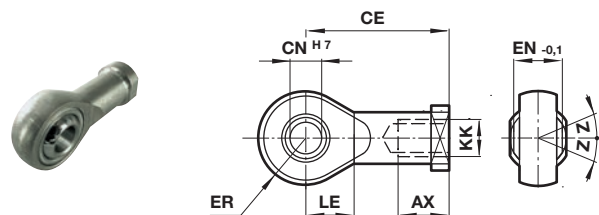

Universal rear eye UR
 Conforms to ISO 15552, type MP6

Dimensions in mm
 Projection/First angle

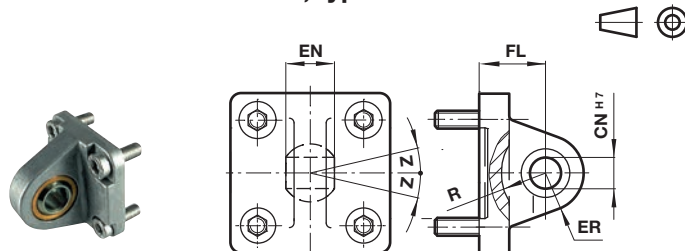

Ø	Thread KK	AX	CE	Ø CN H7	EN -0,1	ER	LE	Z	kg	Model (UF)
32	M10x1,25	20	43	10	14	14	15	13°	0,09	QM/8025/32
40	M12x1,25	22	50	12	16	16	17	13°	0,13	QM/8040/32
50/63	M16x1,5	28	64	16	21	21	22	15°	0,33	QM/8050/32
80/100	M20x1,5	33	77	20	25	25	26	15°	0,67	QM/8080/32

Ø	Ø CN H7	EN	ER	FL	R	Z	kg	Model (UR)
32	10	14	16	22	14,5	13°	0,15	QA/8032/33
40	12	16	18	25	18	13°	0,25	QA/8040/33
50	16	21	21	27	19	15°	0,40	QA/8050/33
63	16	21	23	32	24	15°	0,55	QA/8063/33
80	20	25	28	36	24	15°	0,90	QA/8080/33
100	20	25	30	41	29	15°	1,50	QA/8100/33

Wide hinge SW
 Conforms to ISO 15552, type AB7

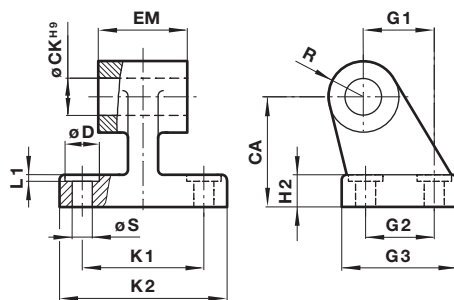

Ø	CA	Ø CK H9	Ø D	H2	EM	G1	G2	G3	K1	K2	L1	R	Ø S	kg	Model (SW)
32	32	10	11	7	25,5	21	18	31	38	50	1,6	10	6,6	0,05	MP19493
40	36	12	11	9	27,5	24	22	35	41	54	1,6	11	6,6	0,07	MP19494
50	45	12	15	11	31,5	33	30	45	50	65	1,6	13	9	0,14	MP19495
63	50	16	15	12	39,5	37	35	50	52	67	1,6	15	9	0,18	MP19496
80	63	16	18	14	49,5	47	40	60	66	84	2,5	15	11	0,28	MP19497
100	71	20	18	15	59,5	55	50	70	76	94	2,5	19	11	0,42	MP19498

Narrow hinge SS

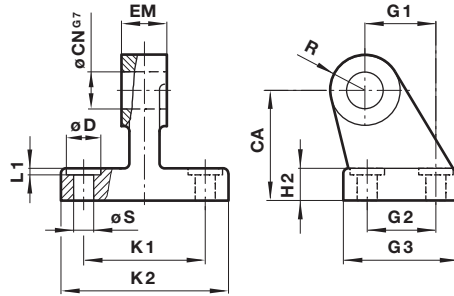

 Dimensions in mm
Projection/First angle

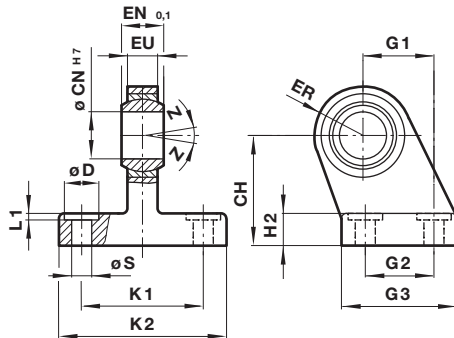
Ø	CA	Ø CN G7	Ø D	H2	EM	G1	G2	G3	K1	K2	L1	R	Ø S	kg	Model (SS)
32	32	10	11	8	10	21	18	31	38	51	1,6	10	6,6	0,15	M/P19931
40	36	12	11	10	12	24	22	35	41	54	1,6	11	6,6	0,20	M/P19932
50	45	16	15	12	16	33	30	45	50	65	1,6	13	9	0,48	M/P19933
63	50	16	15	12	16	37	35	50	52	67	1,6	15	9	0,50	M/P19934
80	63	20	18	14	20	47	40	60	66	86	2,5	15	11	0,75	M/P19935
100	71	20	18	15	20	55	50	70	76	96	2,5	19	11	1,20	M/P19936

**Swivel hinge US
Conforms to VDMA 24562 part 2**

Ø	CH	Ø CN H7	Ø D	EN -0,1	ER	EU	G1	G2	G3	H2	K1	K2	L1	Ø S	Z	kg	Model (US)
32	32	10	11	14	16	10,5	21	18	31	10	38	51	1,6	6,6	13°	0,19	M/P40310
40	36	12	11	16	18	12	24	22	35	10	41	54	1,6	6,6	13°	0,24	M/P40311
50	45	16	15	21	21	15	33	30	45	12	50	65	1,6	9	13°	0,46	M/P40312
63	50	16	15	21	23	15	37	35	50	12	52	67	1,6	9	15°	0,59	M/P40313
80	63	20	18	25	28	18	47	40	60	14	66	86	2,5	11	15°	1,03	M/P40314
100	71	20	18	25	30	18	55	50	70	15	76	96	2,5	11	15°	1,40	M/P40315

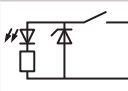
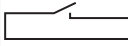
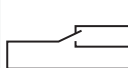
Technical data - Reed switches - additional informations see data sheet N/en 4.3.005

Symbol	Voltage		Current maximum (mA)	Function	Operating temperature (°C)	LED	Protection class	Plug	Cable length (m)	Cable type	Weight (g)	Model
	(V a.c.)	(V d.c.)										
	10 ... 240	10 ... 170	180	Closer	-25 ... +80	•	IP66	—	2, 5 or 10	PVC 2 x 0,25	37	M/50/LSU/*V
	10 ... 240	10 ... 170	180	Closer	-25 ... +80	•	IP66	—	5	PUR 2 x 0,25	37	M/50/LSU/5U
	10 ... 240	10 ... 170	180	Closer	-25 ... +150	—	IP66	—	2	Silicon 2 x 0,25	37	TM/50/RAU/2S
	10 ... 240	10 ... 170	180	Changeover	-25 ... +80	—	IP66	—	5	PVC 3 x 0,25	37	M/50/RAC/5V
	10 ... 60	10 ... 60	180	Closer	-25 ... +80	•	IP66	M8 x 1	0,3	PVC 3 x 0,25	16	M/50/LSU/CP *1)

* Insert cable length; *1) Plug-in connector see page 11; Color code: BK = black, BN = brown, BU = blue

Drawings

M/50/LSU/*V, M/50/LSU/5U,
TM/50/RAU/2S
Cable length L = 2, 5 or 10 m

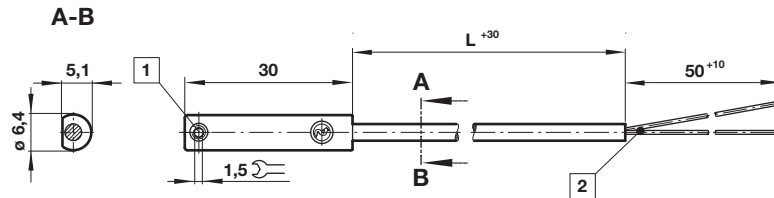

Dimensions in mm
Projection/First angle



M/50/RAC/5V
Cable length L = 5 m

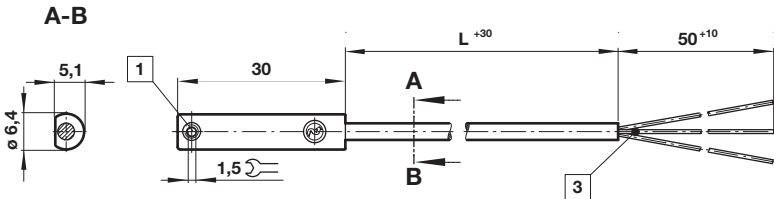

M/50/LSU/CP

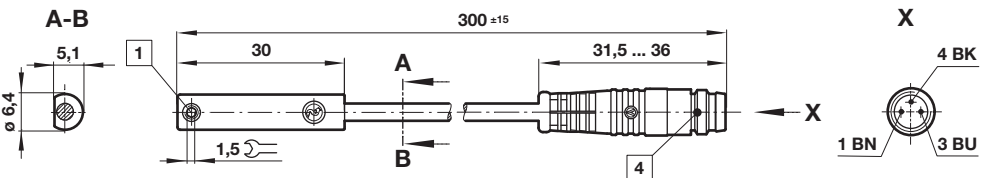

- 1 Fixing screw
- 2 + BN = brown; - BU = blue (output)
- 3 - BK = black; + BN = brown; - ≠BU = blue
- 4 Plug M8 x 1, color code: BK = black; BN = brown; BU = blue

Accessories

Plug-in connector cable with nut



Outer cover	Cable length (m)	Weight (kg)	Connector	Connector
PVC 3 x 0,25	5 m	0,18	M8 x 1	M/P73001/5
PUR 3 x 0,25	5 m	0,18	M8 x 1	M/P73002/5
PUR 3 x 0,34	5 m	0,21	M12 x 1	M/P34594/5

Technical data - Solid state - additional informations see data sheet N/en 4.3.007

Symbol	Voltage (V d.c.)	Current maximum (mA)	Function	Operating temperature (°C)	LED	Protection class	Plug	Cable length (m)	Cable type	Weight (g)	Model
	10 ... 30	150	PNP	-40 ... +80	•	IP67	—	2, 5 or 10	PVC 3 x 0,12	37	M/50/EAP/*V
	10 ... 30	150	PNP	-40 ... +80	•	IP68	—	5	PUR 3 x 0,14	37	M/50/EAP/5U
	10 ... 30	150	PNP	-40 ... +80	•	IP67	M8 x 1	0,3	PVC 3 x 0,14	16	M/50/EAP/CP *1)
	10 ... 30	150	PNP	-40 ... +80	•	IP67	M12 x 1	0,3	PVC 3 x 0,14	16	M/50/EAP/CC *1)
	10 ... 30	150	NPN	-40 ... +80	•	IP67	—	2, 5 or 10	PVC 3 x 0,12	37	M/50/EAN/*V
	10 ... 30	150	Closer	-40 ... +80	•	IP67	M8 x 1	0,3	PVC 3 x 0,14	16	M/50/EAN/CP *1)

* Insert cable length; *1) Plug-in connector below; Color code: BK = black, BN = brown, BU = blue

Drawings

M/50/EAP/*V,
M/50/EAN/*V
Cable length L = 2, 5 or 10 m

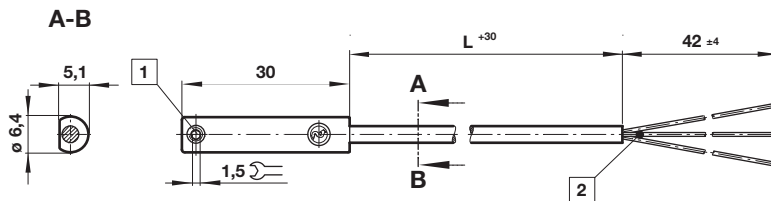

Dimensions in mm
Projection/First angle



M/50/EAP/CP,
M/50/EAN/CP

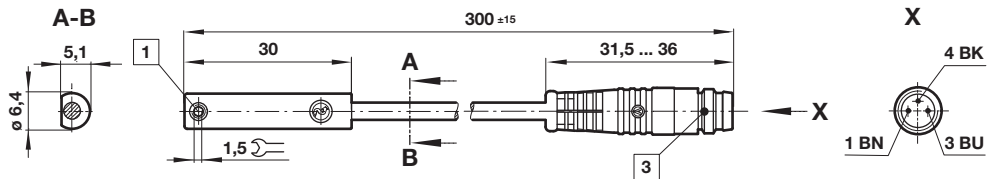

M/50/EAP/CC

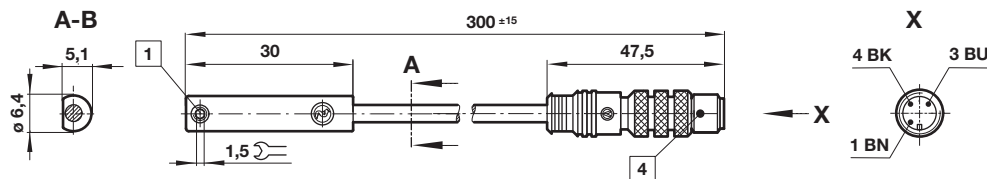

- 1 Fixing screw
- 2 Color code: BK = black; BN = brown; BU = blue
- 3 Plug M8 x 1
- 4 Plug M12 x 1

QM/27/2/1 – Switch mounting brackets

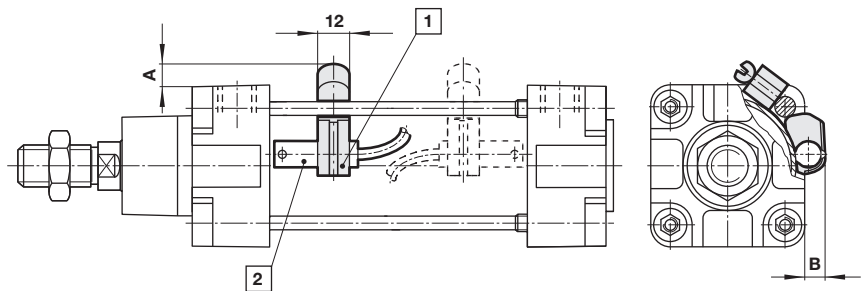

Switch: M/50

Cyl. Ø	A	B	Weight (kg)	Model
32	9	7	0,010	QM/27/2/1
40	8	8	0,010	QM/27/2/1
50	7	5	0,010	QM/27/2/1
63	7	7	0,010	QM/27/2/1
80	7	4	0,010	QM/27/2/1
100	2	2	0,010	QM/27/2/1

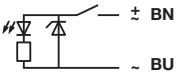
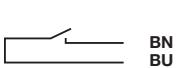

- 1 Switch mounting bracket
- 2 Magnetically operated switch

Technical data - Reed switches - additional informations see data sheet N/en 4.3.021

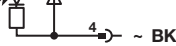
Symbol	Voltage (V a.c./V d.c.)	Current maximum (A)	Function	Operating temperature (°C)	LED	Protection class	Features	Cable length (m)	Cable type	Weight (g)	Model
	10 ... 240	1	Closer	-20 ... +80	•	IP66	—	2, 5 or 10	PVC 2 x 0,75	108 (2 m)	QM/32/*
	10 ... 240	1	Closer	-20 ... +80	•	IP66	—	2	PUR 2 x 0,75	108	QM/32/2/PU
	10 ... 240	2	Closer	-20 ... +150	—	IP66	High temperature	2, 5 or 10	Silicon 2 x 0,75	102 (2 m)	TQM/31/*
	10 ... 240	1	Closer	-20 ... +80	•	IP66	Plug M12 x 1	—	—	15	QM/32/P *1)

Technical data - Solid state - additional informations see data sheet N/en 4.3.025

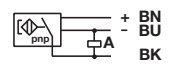
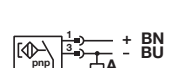
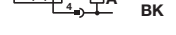
Symbol	Voltage (V d.c.)	Current maximum (mA)	Function	Temperature (°C)	LED	Protection class	Features	Cable length (m)	Cable type	Weight (g)	Model
	10 ... 30	200	PNP	-20 ... +80	•	IP66	—	2, 5 or 10	PVC 3 x 0,5	102 (2 m)	QM/132/*
	10 ... 30	200	PNP	-20 ... +80	•	IP66	—	5	PUR 3 x 0,34	—	QM/132/5/PU
	10 ... 30	200	PNP	-20 ... +80	•	IP66	Plug M12 x 1	—	—	15	QM/132/P *1)

* Insert cable length

*1) Plug-in connector see page below; Color code: BK = black, BN = brown, BU = blue

Drawings

TQM/31, QM/32, QM/132

QM/32/P, QM/132/P

Dimensions in mm
Projection/First angle

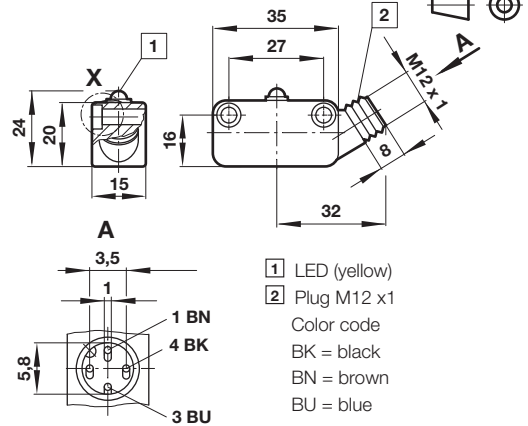
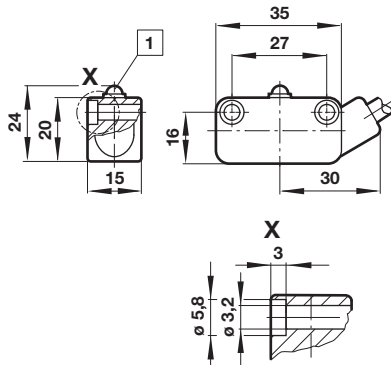

- 1 LED (yellow)
- 2 Plug M12 x1
- Color code
- BK = black
- BN = brown
- BU = blue

Accessories

Plug-in connector cable with nut



Outer cover	Cable length (m)	Weight (kg)	Connector	Connector
PVC 3 x 0,34	5 m	0,21	M12 x 1	M/P34692/5
PUR 3 x 0,34	5 m	0,21	M12 x 1	M/P34594/5

QM/31/000/22 – Switch mounting brackets
Switches: TQM/31, QM/32, QM/132

 Dimensions in mm
 Projection/First angle

Cyl. Ø	A	B	Weight (kg)	Model
32	4,5	38	0,026	QM/31/032/22
40	5,5	43	0,026	QM/31/032/22
50	4,5	48	0,026	QM/31/032/22
63	4,5	53	0,026	QM/31/032/22
80	1,5	61	0,028	QM/31/080/22
100	0,5	68	0,028	QM/31/080/22

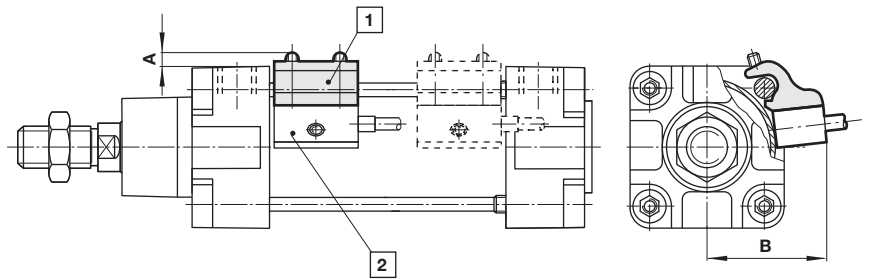

- 1 Bracket
- 2 Switch

Pneumatic proximity sensor - additional informations see data sheet N/en 4.3.061

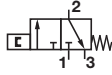
Symbol	Operating pressure	Flow rate	Orifice size	Temperature	Optical indicator	Connections	Model
	2 ... 6 bar	40 l/min	2 mm	-15 ... +60°C	•	Pipes for 3 mm I/D tubing	QM/140

QM/140/010/22 – Bracket with holding strap
Pneumatic switch: QM/140

Cyl. Ø	A	B	Weight (kg)
32	31,5	18,5	0,020
40	30,5	18,5	0,020
50	31,5	18,5	0,020
63	29,5	18,5	0,020
80	30,5	18,5	0,020
100	30	18,5	0,020

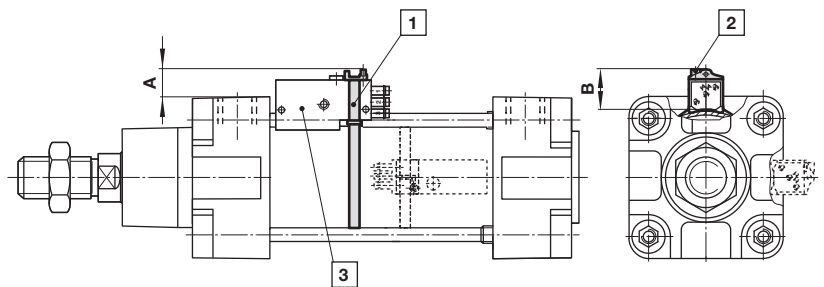

- 1 Holding strap
- 2 Optical indicator
- 3 Pneumatic switch

Warning

These products are intended for use in industrial compressed air systems only. Do not use these products where pressures and temperatures can exceed those listed under

»**Technical features/data**«.

Before using these products with fluids other than those specified, for non-industrial applications, life-support systems or other applications not within published specifications, consult IMI NORGREN.

Through misuse, age, or malfunction, components used in fluid power systems can fail in various modes.

The system designer is warned to consider the failure modes of all component parts used in fluid power systems and to provide adequate safeguards to prevent personal injury or damage to equipment in the event of such failure.

System designers must provide a warning to end users in the system instructional manual if protection against a failure mode cannot be adequately provided.

System designers and end users are cautioned to review specific warnings found in instruction sheets packed and shipped with these products.